

# PROLUMIA®

**LED PRO-PORTAL**

+ EMERGENCY MODE

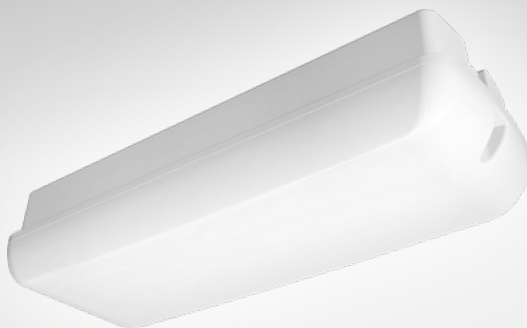

## OPERATING INSTRUCTION

GEBRUIKSAANWIJZING  
MANUEL D'UTILISATION  
INSTALAČNÍ NÁVOD  
GEBRAUCHSANLEITUNG

4001002x	Pro-Portal + Emergency mode
4001003x	Pro-Portal + Microwave sensor + Emergency mode

CE IP65 □

## ATTENTIE

Lees de volgende instructies zorgvuldig door om ervoor te zorgen dat de montagewerkzaamheden op de juiste manier worden uitgevoerd. Bewaar deze instructies goed voor eventueel toekomstig gebruik.

## OPGELET

1. Het product dient te worden geïnstalleerd door gekwalificeerde personen. De installatie dient, voorafgaand aan de montage, spanningsloos te worden gemaakt.
2. De installatiedraad moet minimaal 2 x 1,0 mm<sup>2</sup> zijn en worden aangesloten in overeenstemming met de laatste elektriciteitsvoorschriften van IEE of volgens de nationale eisen.
3. Sluit de stroomtoevoer van de voeding af voordat u de accu vervangt.
4. Raak het elektronische circuit en de componenten niet aan.
5. Indien de autonomie van 1 uur niet meer wordt gehaald, dient de accu vervangen te worden.
6. Neem contact op met een erkende technische service center voor het vervangen van de accu en gebruik alleen originele onderdelen voor andere reparaties.
7. Identificatie code van de accu productiedatum: ex.1810 --- 2018, week10.
8. Raak de LED's niet aan tijdens installatie of onderhoud.
9. De LED lichtbron van de lamp kan niet worden vervangen. Het volledige product dient te worden vervangen als de lichtbron defect is.
10. Door zelfontlading neemt de lading van de accu, als deze niet op het net is aangesloten, langzaam af. Dit kan leiden tot schade aan de accu bij langdurige spanningsloosheid. De hierdoor ontstane schade valt niet onder garantie.
11. Op veel bouwplaatsen kunnen stroomcircuits worden onderbroken op een ongecontroleerde en repetitieve basis tijdens de bouw. Accu's kunnen als gevolg hiervan leeglopen. Het frequent laden en ontladen van de accu zal de levensduur verkorten en kan leiden tot voortijdig falen van de accu. De hierdoor ontstane schade valt niet onder garantie.

## TECHNISCHE DATA

Voedingsspanning: AC 220-240V 50/60Hz

Lichtbron: LED SMD2835

Accu: Ni-Cd Duur: 1 uur

Bedrijfstemperatuur: -20°C - +50°C

Elektrische veiligheidsklasse: Klasse II

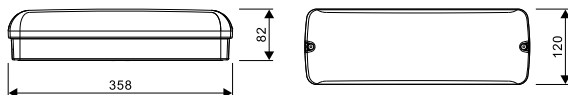

## TECHNISCHE INFORMATIE

Artikelnr.	Type LED	Vermogen	Lichtstroom schakelbaar	Lichtstroom noodbedrijf	Sensor	Werking	Duur	Accu
4001002x	SMD2835	7,5W	600Lm / 300Lm	200Lm	-	(Niet-)permanent (schakelbaar)	1 uur	Ni-CD 2/3AA450mAhHT 7.2V
4001003x	SMD2835	8,5W	600Lm / 300Lm	200Lm	Ja	(Niet-)permanent (schakelbaar)	1 uur	Ni-CD 2/3AA450mAhHT 7.2V

## MICROWAVE SENSOR - BESCHRIJVING

Detectiebereik max. (D x H): 14m x 6m

Detectie-gevoeligheid: 25% - 100%, instelbaar

Brandduur: 5sec - 30min, instelbaar

Daglicht 1: 5 - 15Lux, instelbaar of uitschakelen

Daglicht 2: 35 - 150Lux, instelbaar of uitschakelen (bij daglichtprioriteit)

Nalooptijd: 5 - 30sec - 1 - 5 - 15 - 30min (instelbaar)

Nalooptijd oriëntatieverlichting:

0 - 10 - 20 - 30 - 60 - ∞ min (instelbaar)

Montagehoogte: 6m max.

Bewegingsdetectie: 0,5 ~ 3m/s

Detectiehoek: 150° (wandmontage),

360° (plafondmontage)

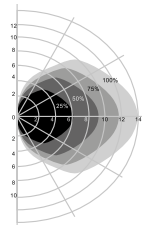

Detectiebereik wandmontage (Eenheid: m)  
Voorgestelde montagehoogte: 1 - 1,8m

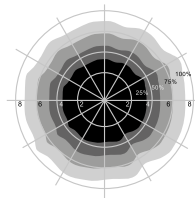

Detectiebereik plafondmontage (Eenheid: m)  
Voorgestelde montagehoogte: 2,5 - 6m

## MICROWAVE SENSOR - INSTELLING PARAMETERS

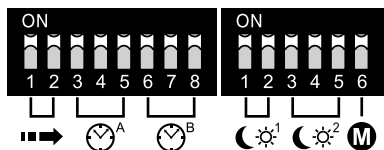

### ➡ Detectiebereik

Dit bepaalt het effectieve bereik van de bewegingsmelder en wordt met de micro-schakelaars op de sensor ingesteld, zie figuur onder. Wees er van bewust dat het verminderen van de gevoeligheid ook het detectiebereik zal verkleinen.

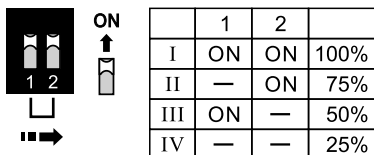

### ⌚<sup>B</sup> Nalooptijd oriëntatieverlichting

Gedurende deze periode zal het armatuur op laag niveau (20%) branden. Wanneer deze is ingesteld op +∞ geeft het armatuur permanent 20% licht als er geen beweging gedetecteerd wordt. Dit wordt ingesteld met micro-schakelaars op de sensor, zie figuur onder.

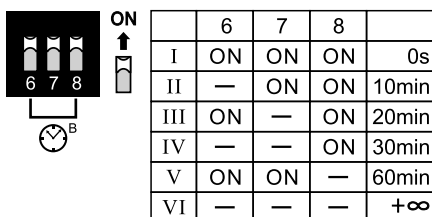

### ☀<sup>2</sup> Daglicht 2

Dit is alleen van toepassing onder modus 2. Het verwijst naar het daglichtniveau waaronder het armatuur op laag niveau gaat branden.

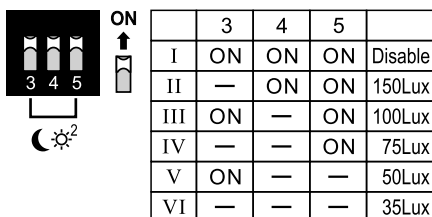

### ⌚<sup>A</sup> Nalooptijd

Dit bepaalt de tijd dat het armatuur op 100% niveau blijft branden. Dit kan worden ingesteld met micro-schakelaars op de sensor, zie figuur onder. Tijdens het installeren van het armatuur is de looptest-instelling (5s) handig om de juiste werking en het bereik vast te stellen.

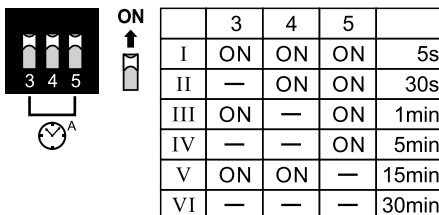

### ☀<sup>1</sup> Daglicht 1

Hiermee kan de sensor het armatuur inschakelen wanneer het omgevingslicht volledig daglicht (15Lux), weinig daglicht (10Lux) of donker (5Lux) is. Ook kan de sensor hiermee worden uitgeschakeld. Dit wordt ingesteld met micro-schakelaars op de sensor, zie figuur onder. Zolang het lichtniveau boven de ingestelde waarde ligt, zal het armatuur bij bewegingsdetectie uitbliven.

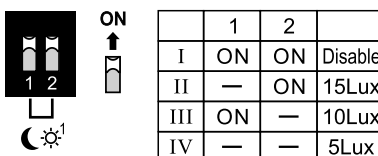

### Ⓜ Mode

Modus 1: Armatuur blijft uit bij bewegingsdetectie indien het daglichtniveau boven de bij "Daglicht 1" ingestelde waarde ligt. Modus 2: Indien het daglichtniveau onder de bij "Daglicht 2" ingestelde waarde komt, zal het armatuur op laag niveau gaan branden. Bij bewegingsdetectie wordt opgeschakeld naar 100%.

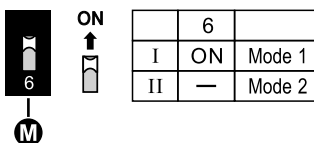

# MICROWAVE SENSOR - INSTELLING PARAMETERS

## A 0% / 100% / 20%

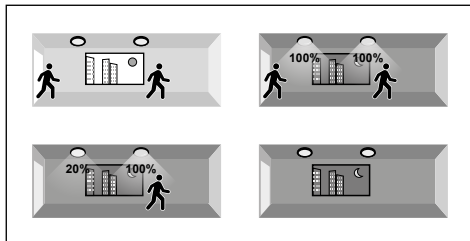

**M** Modus

ON	6		
I	ON	Mode 1	✓
II	—	Mode 2	

**N** Nalooptijd

ON	6	7	8	
I	ON	ON	ON	0s
II	—	ON	ON	10min
III	ON	—	ON	20min
IV	—	—	ON	30min
V	ON	ON	—	60min
VI	—	—	—	+∞

## B 0% / 100%

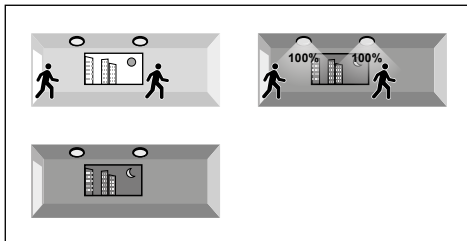

**M** Modus

ON	6		
I	ON	Mode 1	✓
II	—	Mode 2	

**N** Nalooptijd

ON	6	7	8	
I	ON	ON	ON	0s
II	—	ON	ON	10min
III	ON	—	ON	20min
IV	—	—	ON	30min
V	ON	ON	—	60min
VI	—	—	—	+∞

## C 20% / 100%

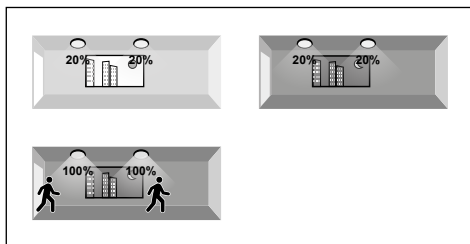

**M** Modus

ON	6		
I	ON	Mode 1	✓
II	—	Mode 2	

**N** Nalooptijd

ON	6	7	8	
I	ON	ON	ON	0s
II	—	ON	ON	10min
III	ON	—	ON	20min
IV	—	—	ON	30min
V	ON	ON	—	60min
VI	—	—	—	+∞

## D 0% / 20% op basis van daglicht / 100% bij beweging

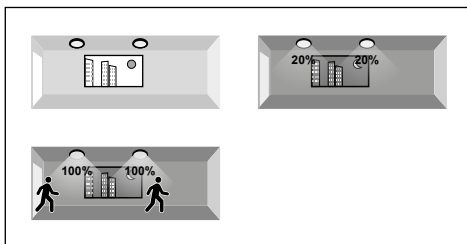

**M** Modus

ON	6		
I	ON	Mode 1	✓
II	—	Mode 2	

## KEUZE LICHTOPBRENGST

U kunt het armatuur instellen op 2 verschillende Lumen waarden:

ON - 600Lm (standaard)

1 - 300Lm

De schakelaar is te vinden naast de LED module en is te zien wanneer u de beschermingskap heeft verwijderd.

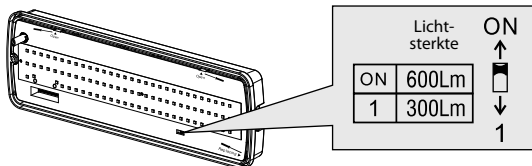

## MASTER/SLAVE FUNCTIE

### Functie A

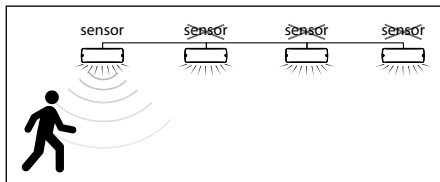

### Functie B

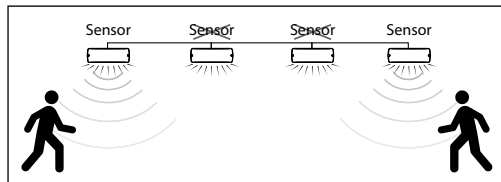

### Functie A - Centraal geschakeld

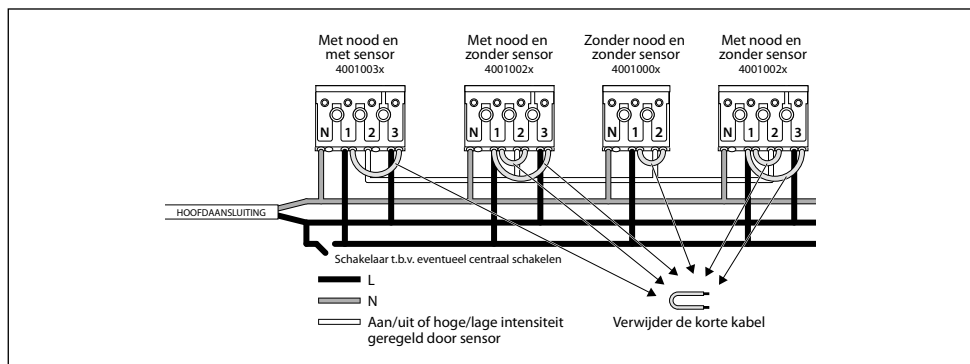

### Functie B - Alleen geschakeld d.m.v. ingebouwde sensoren

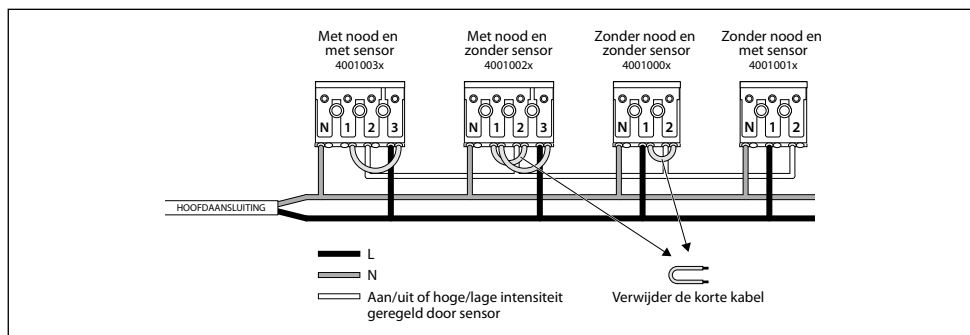

**!** Het aantal units in slave-functie is gelimiteerd. (Max. 60 stuks)

## MONTAGE

1. Draai de afscherming los en open het LED paneel.
2. Haal het aansluitsnoer door de thule en fixeer met de trekcontlasting.
3. Bevestig het armatuur d.m.v. schroeven op de ondergrond.
4. Sluit het aansluitsnoer correct aan op de terminal.
5. Sluit de stekker van de accu aan op de "Battery +/-" aansluiting van de noodunit. 
6. Sluit het LED paneel en bevestig de afscherming.

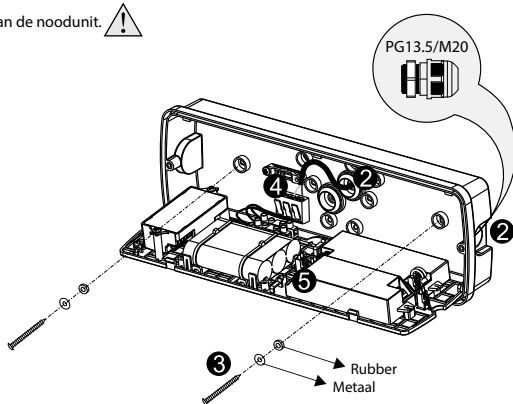
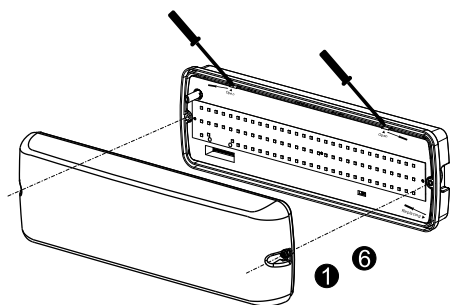

### 4 Aansluiting kabel

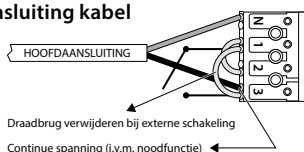

Nood versie

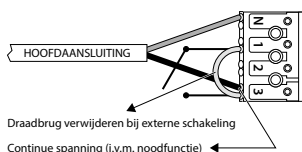

Nood + Sensor versie  
(geschakelde fase niet verplicht)

## TESTEN

Test noodfunctie na de installatie.

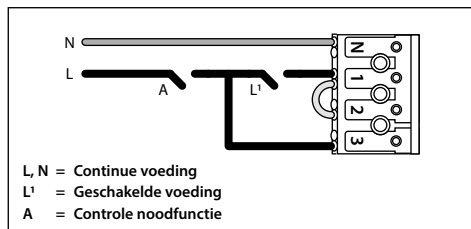

## ACCESSOIRES - NOODUITGANG SYMBOLEN



40010040  
Nooduitgang  
Omhoog



40010041  
Nooduitgang  
Omlaag



40010042  
Nooduitgang  
Links



40010043  
Nooduitgang  
Rechts

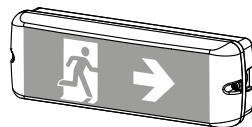

## ACCU VERVANGEN

1. Maak het armatuur eerst spanningsloos.
2. Trek de plug van de accu uit de noodunit.
3. Verwijder de plastic bevestigingen.
4. Verwijder de oude accu.
5. Bevestig de nieuwe accu d.m.v. de plastic bevestigingen.
6. Sluit de stekker aan op de noodunit.
7. Noteer de datum van ingebruikname van de accu.

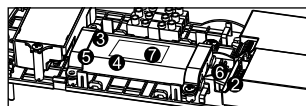

## BINNENWERK VERVANGEN

**!** Maak het armatuur eerst spanningsloos.

1. Maak de beschermkap los, verwijder daarna met een schroevendraaier de LED driver.
2. Haal de male-female-stekkers van elkaar en verwijder het oude binnenwerk.
3. Monteer het nieuwe binnenwerk en sluit vervolgens de male-female-stekkers stevig aan.
4. Bevestig de beschermkap.

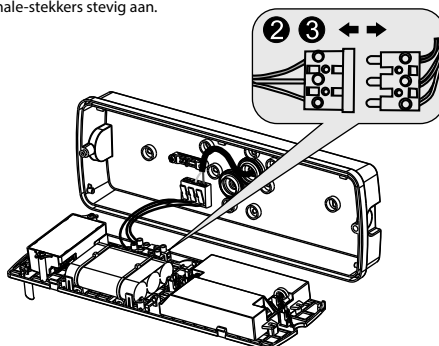
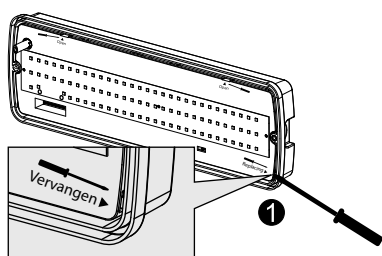

## ONDERHOUD

1. Maak het armatuur spanningsloos.
2. Raak de LED's niet aan tijdens onderhoud of schoonmaak.
3. Gebruik geen chemische schoonmaakmiddelen om de lamp te reinigen.

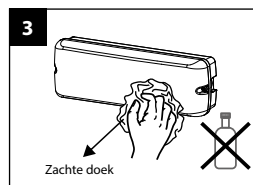
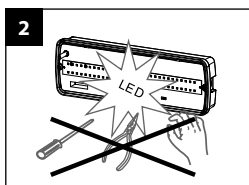
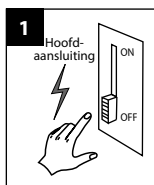

## BESCHERMING VAN HET MILIEU

Defecte elektrische apparaten behoren niet te worden weggegooid bij het huishoudelijk afval. Recycle waar mogelijk. Neem contact op met uw gemeente of uw leverancier voor een deskundig recycling advies.



## ATTENTION

Please read the following instructions carefully to ensure that mounting operation will be carried out correctly. These instructions should be properly preserved for future reference.

## CAUTION

1. The product must be installed by qualified technicians. The power supply must be cut before installation.
2. The installation wiring must be  $2 \times 1.0 \text{ mm}^2$  at least and wired in accordance with the latest IEE electrical regulations or the national requirements.
3. Cut the power supply before replacing battery.
4. Do not touch the electronic circuit and its components.
5. When fixture is unable to maintain the 1 hour duration under battery operation, then the battery must be replaced.
6. Contact an authorised technical service center for the replacement of the battery and use only original manufacturer spare parts for any other repairs.
7. Code for identification of battery production date: ex.1810 --- 2018, week10.
8. Do not touch the LEDs while installing or maintaining.
9. The LED light source of the lamp cannot be replaced. The complete product must be replaced if the light source is defect.
10. The charge of the battery will decrease by self-discharge if not connected to mains supply. Prolonged periods without voltage can damage the battery. Battery warranty claims, as a result of such abuse, are specifically EXCLUDED from warranty terms.
11. On many building sites, power circuits may be cut off in an uncontrolled and repetitive basis during construction. As a result, any unit on these circuits, will have their batteries discharged or 'cycled'. Excessive battery cycling will reduce through-life performance and may lead to premature battery failure. Battery warranty claims, as a result of such abuse, are specifically EXCLUDED from warranty terms.

## TECHNICAL DATA

Supply voltage: AC 220-240V 50/60Hz

Light source: LED SMD2835

Batteries: Ni-Cd Duration: 1h

Operating temperature:  $-20^{\circ}\text{C}$  -  $+50^{\circ}\text{C}$

Electrical safety class: Class II

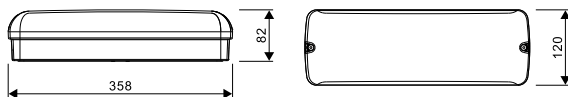

## TECHNICAL INFORMATION

Art.no.	LED type	Input power	Lumen switchable	Lumen Emergency mode	Sensor	Mode of operation	Duration	Battery
4001002x	SMD2835	7.5W	600Lm / 300Lm	200Lm	-	(Non) maintained (switchable)	1h	Ni-CD 2/3AA450mAhHT 7.2V
4001003x	SMD2835	8.5W	600Lm / 300Lm	200Lm	Yes	(Non) maintained (switchable)	1h	Ni-CD 2/3AA450mAhHT 7.2V

## MICROWAVE SENSOR - DESCRIPTION

Detection zone max. (d x h): 14m x 6m

Detection sensitivity: 25% - 100%, adjustable

Hold time: 5sec - 30min, adjustable

Daylight 1: 5 - 15Lux, adjustable or disable

Daylight 2: 35 - 150Lux, adjustable or disable (with daylight priority)

Hold time: 5 - 30sec - 1 - 5 - 15 - 30min (adjustable)

Hold time orientation lighting:

0 - 10 - 20 - 30 - 60 -  $\infty$  min (adjustable)

Mounting height: 6m max.

Motion detection: 0.5 ~ 3m/s

Detection angle:  $150^{\circ}$  (wall installation),

$360^{\circ}$  (ceiling installation)

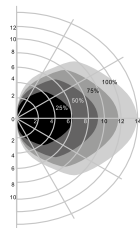

Wall mounting detection area (Unit: m)  
Suggested installation height: 1 - 1.8m

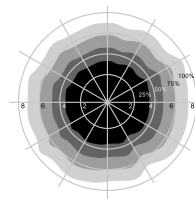

Ceiling mounting detection area (Unit: m)  
Suggested installation height: 2.5 - 6m



## MICROWAVE SENSOR - PARAMETER SETTINGS

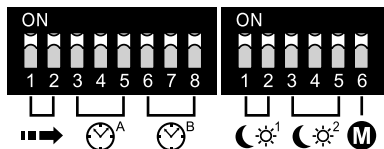

### ➡ Detection Area

This determines the effective range of the motion detector and is set with DIP switches on the sensor, please see figure below. Note that reducing the sensitivity will also narrow the detection range.

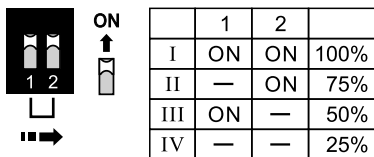

	1	2	
I	ON	ON	100%
II	—	ON	75%
III	ON	—	50%
IV	—	—	25%

### 🕒<sup>A</sup> Hold Time

This determines the time the fixture remains at 100% and is set with DIP switches on the sensor, please see figure below. The walk test (5s) setting is useful when installing the fixture to establish correct operation and range.

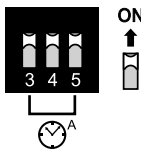

	3	4	5	
I	ON	ON	ON	5s
II	—	ON	ON	30s
III	ON	—	ON	1min
IV	—	—	ON	5min
V	ON	ON	—	15min
VI	—	—	—	30min

### 🕒<sup>B</sup> Hold time orientation lighting

During this period, the fixture will light up at low level (20%). When this is set to +∞, the fixture gives permanent 20% light when no movement detected. It is set with DIP switches on the sensor, please see figure below.

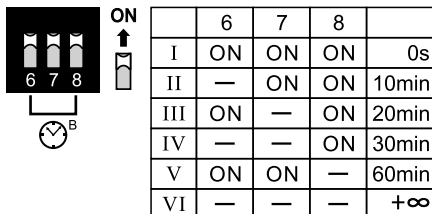

	6	7	8	
I	ON	ON	ON	0s
II	—	ON	ON	10min
III	ON	—	ON	20min
IV	—	—	ON	30min
V	ON	ON	—	60min
VI	—	—	—	+∞

### ☀️<sup>1</sup> Daylight 1

This allows the sensor to switch the unit on when daylight level is either full daylight (15Lux), low daylight (10Lux), or after dark (5Lux). It also allows the sensor to be disabled. As long as the light level is above the set point, the fixture will stay off when motion is detected.

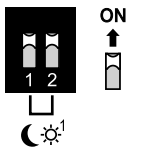

	1	2	
I	ON	ON	Disable
II	—	ON	15Lux
III	ON	—	10Lux
IV	—	—	5Lux

### ☀️<sup>2</sup> Daylight 2

This is only applicable under mode 2. Under this daylight level the fixture will light at low level.

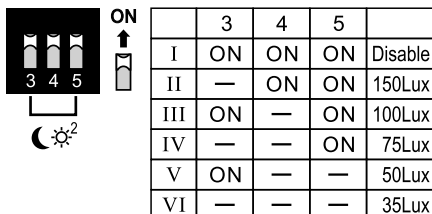

	3	4	5	
I	ON	ON	ON	Disable
II	—	ON	ON	150Lux
III	ON	—	ON	100Lux
IV	—	—	ON	75Lux
V	ON	—	—	50Lux
VI	—	—	—	35Lux

### Ⓜ Mode

Mode 1: Fixture remains off during motion if the daylight level is above the value set at "Daylight 1".

Mode 2: When the daylight level falls below the value set under "Daylight 2", the fixture will light at low level. When motion is detected, it is shifting to 100%.

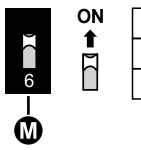

	6	
I	ON	Mode 1
II	—	Mode 2

# MICROWAVE SENSOR - PARAMETER SETTINGS

## A 0% / 100% / 20%

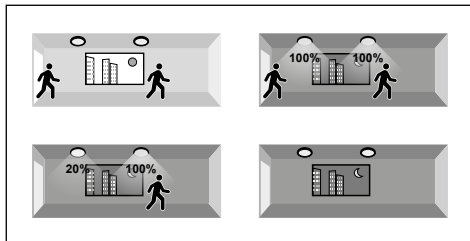

**M** Mode

ON	6		
I	ON	Mode 1	✓
II	—	Mode 2	

**M**

**⌚** Hold time

ON	6	7	8	
I	ON	ON	ON	0s
II	—	ON	ON	10min
III	ON	—	ON	20min
IV	—	—	ON	30min
V	ON	ON	—	60min
VI	—	—	—	+∞

## B 0% / 100%

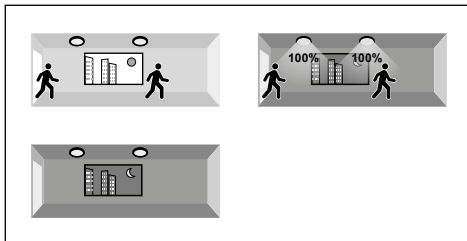

**M** Mode

ON	6		
I	ON	Mode 1	✓
II	—	Mode 2	

**M**

**⌚** Hold time

ON	6	7	8	
I	ON	ON	ON	0s
II	—	ON	ON	10min
III	ON	—	ON	20min
IV	—	—	ON	30min
V	ON	ON	—	60min
VI	—	—	—	+∞

## C 20% / 100%

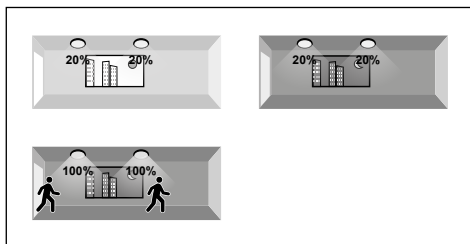

**M** Mode

ON	6		
I	ON	Mode 1	✓
II	—	Mode 2	

**M**

**⌚** Hold time

ON	6	7	8	
I	ON	ON	ON	0s
II	—	ON	ON	10min
III	ON	—	ON	20min
IV	—	—	ON	30min
V	ON	ON	—	60min
VI	—	—	—	+∞

## D 0% / 20% based upon daylight / 100% when triggered

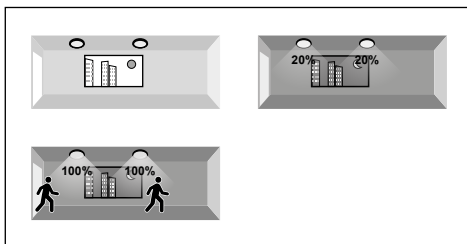

**M** Mode

ON	6		
I	ON	Mode 1	✓
II	—	Mode 2	

**M**

## OPTIONAL OUTPUT BRIGHTNESS

There are two choices of output brightness by different setting on the surface of the LED light engine:

- ON - 600Lm (standard)
- 1 - 300Lm

The switch can be found next to the LED module and can be seen when you have removed the protective cap.

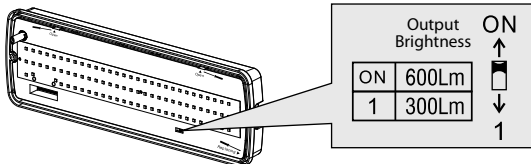

## MASTER/SLAVE FUNCTION

### Function A

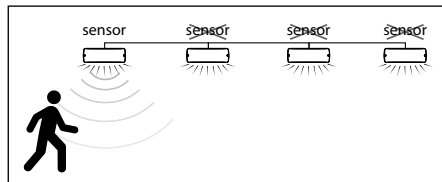

### Function B

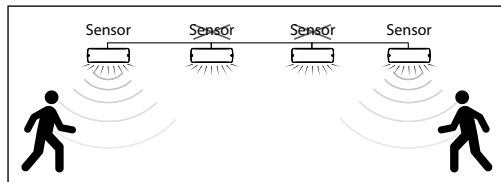

### Function A - Central switched

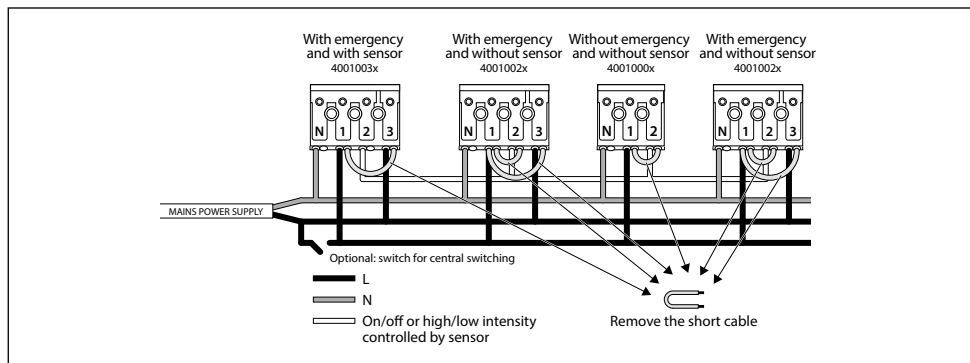

### Function B - Only switched by means of built-in sensors

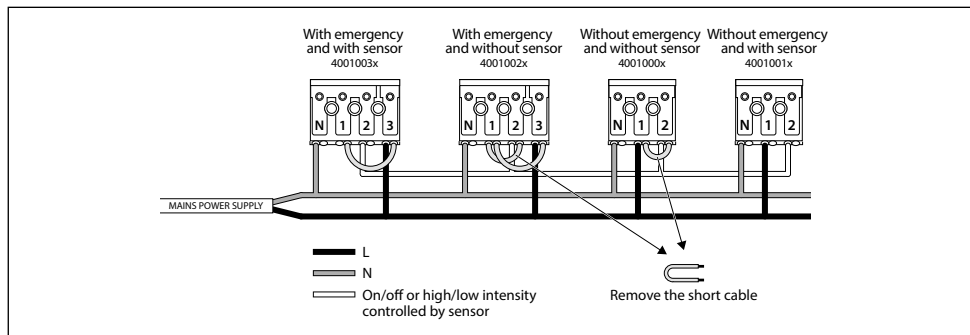

The number of slaves is limited. (Max. 60pcs)

## MOUNTING

1. Disassemble the diffuser and LED panel.
2. Pull the power cord through the gasket.
3. Fix the fixture on the surface with screws.
4. Connect the power cord on the terminal correctly.
5. Connect the plug of the battery firmly onto the emergency driver. 
6. Assemble the LED panel and diffuser.

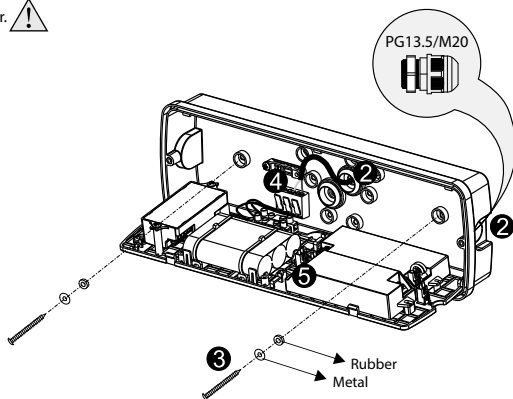
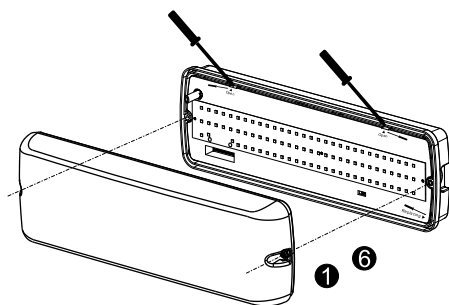

### 4 Cable connection

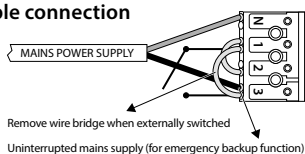

Emergency mode version

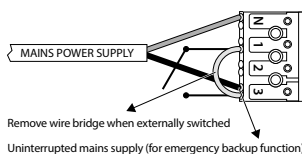

Emergency mode + Sensor version  
(switched phase not required)

## TESTING

Test emergency function after installation.

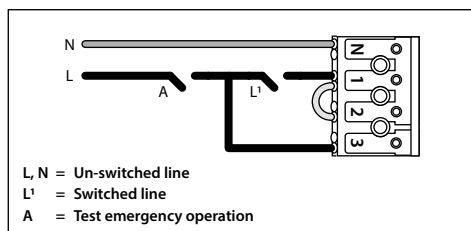

## ACCESSORIES - EXIT SIGNS



40010040  
Exit sign  
Up



40010041  
Exit sign  
Down



40010042  
Exit sign  
Left



40010043  
Exit sign  
Right

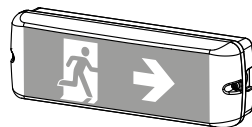

## HOW TO REPLACE BATTERIES

1. Cut the power supply first.
2. Pull out the plug of batteries from the emergency driver.
3. Screw out the plastic fixers.
4. Remove the old batteries.
5. Fix the new batteries by plastic fixers.
6. Connect the plug onto the emergency driver.
7. Record the date of commissioning of the batteries.

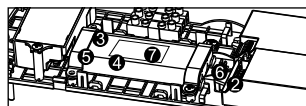

## REPLACING THE LIGHT ENGINE

**⚠ Cut off the mains power first.**

1. Open the diffuser, then remove the LED light engine using tool.
2. Separate the male-female terminals, and remove the old light engine.
3. Assemble the new light engine, then connect the male-female terminals firmly.
4. Fix the diffuser.

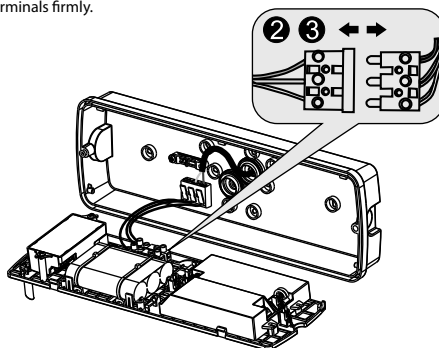
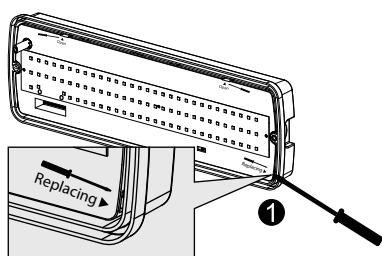

## MAINTENANCE

1. Cut off the mains power first.
2. Don't touch LED while maintaining or cleaning.
3. Don't use chemical reagent to clean lamp.

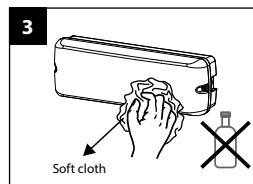
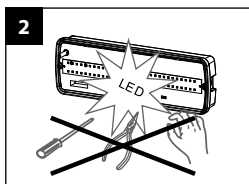
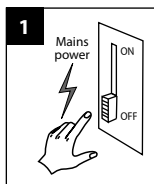

## ENVIRONMENTAL PROTECTION

Waste electrical products should not be disposed of with household waste. Please recycle where facilities exist. Check with your local authority or retailer for recycling advice.



## ATTENTION

Lisez attentivement les instructions suivantes pour vous assurer que les travaux d'installation sont effectués correctement.  
Conservez ces instructions en toute sécurité pour une utilisation future possible.

## ATTENTION

1. Le produit doit être installé par des personnes qualifiées. L'installation doit être mise hors tension avant l'installation.
2. Le câble d'installation doit avoir au moins  $2 \times 1,0 \text{ mm}^2$  et doit être raccordé conformément aux dernières réglementations électriques de l'IEE ou selon les exigences nationales.
3. Débranchez l'alimentation avant de remplacer la batterie.
4. Ne touchez pas le circuit électronique et les composants.
5. Si l'autonomie de 1 heure n'est plus atteinte, la batterie doit être remplacée.
6. Contactez un centre de service technique reconnu pour remplacer la batterie et n'utilisez que des pièces d'origine pour d'autres réparations.
7. Code d'identification de la date de production de la batterie: ex.1810 --- 2018, semaine10.
8. Ne touchez pas les voyants pendant l'installation ou la maintenance.
9. La source de lumière LED de la lampe ne peut pas être remplacée. Le produit complet doit être remplacé si la source lumineuse est défectueuse.
10. En se déchargeant automatiquement, la charge de la batterie, si elle n'est pas connectée au secteur, diminue lentement. Cela peut entraîner des dommages à la batterie pendant une période de sans tension prolongée. Les dommages qui en résultent ne sont pas couverts par la garantie.
11. Sur de nombreux sites de construction, les circuits de courant peuvent être interrompus de manière incontrôlée et répétitive pendant la construction. En conséquence, les batteries peuvent se décharger. La charge et la décharge fréquente de la batterie réduiront sa durée de vie et entraîneront une défaillance prématurée de la batterie. Les dommages qui en résultent ne sont pas couverts par la garantie.

## DONNÉES TECHNIQUES

Tension d'alimentation: AC 220-240V 50/60Hz

Source de lumière: LED SMD2835

Batterie: Ni-Cd Durée: 1 heure

Température de fonctionnement: -20°C - +50°C

Classe de protection électrique: Classe II

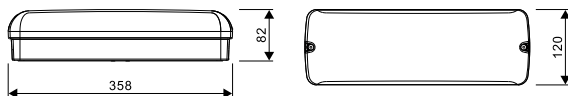

## INFORMATIONS TECHNIQUES

Número article	Type LED	Puissance	Le flux lumineux peut être commuté	Fonctionnement d'urgence du flux lumineux	Capteur	Fonctionnement	Cher	Batterie
4001002x	SMD2835	7,5W	600Lm / 300Lm	200Lm	-	(Non-) permanent (commutable)	1 heure	Ni-CD 2/3AA450mAhHT 7.2V
4001003x	SMD2835	8,5W	600Lm / 300Lm	200Lm	Oui	(Non-) permanent (commutable)	1 heure	Ni-CD 2/3AA450mAhHT 7.2V

## CAPTEUR DE MICRO-ONDES - DESCRIPTION

Plage de détection maxi (D x H): 14m x 6m

Sensibilité de détection: 25% - 100%, réglable

Temps de combustion: 5sec - 30min, réglable

Lumière du jour 1: 5 - 15Lux, réglable ou désactiver

Lumière du jour 2: 35 - 150Lux, réglable ou désactiver (en priorité jour)

Temps de suivi: 5 - 30sec - 1 - 5 - 15 - 30min (réglable)

Temps de suivi lumière d'orientation:

0 - 10 - 20 - 30 - 60 - ∞ min (réglable)

Hauteur d'installation: 6m max.

Détection de mouvement: 0,5 ~ 3m/s

Angle de détection: 150° (montage mural),

360° (montage au plafond)

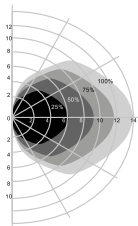

Portée de détection montage mural (Unité: m)  
Hauteur de montage proposée: 1 - 1,8m

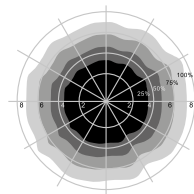

Portée de détection montage au plafond (Unité: m)  
Hauteur de montage proposée: 2,5 - 6m

## CAPTEUR DE MICRO-ONDES - RÉGLAGE DES PARAMÈTRES

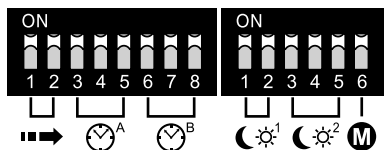

### Portée de détection

Ceci détermine la portée effective du détecteur de mouvement et sera réglé par les micro-interrupteurs sur le capteur, voir la figure ci-dessous. Sachez que réduire la sensibilité réduira également la plage de détection.

	1	2	
I	ON	ON	100%
II	—	ON	75%
III	ON	—	50%
IV	—	—	25%

### Temps de suivi éclairage d'orientation

Pendant cette période, le luminaire brûlera au niveau bas (20%). Lorsque ce paramètre est réglé sur +∞, le luminaire s'allume en permanence 20% si aucun mouvement n'est détecté. Ceci est réglé par des micro-interrupteurs sur le capteur, voir la figure ci-dessous.

	6	7	8	
I	ON	ON	ON	0s
II	—	ON	ON	10min
III	ON	—	ON	20min
IV	—	—	ON	30min
V	ON	ON	—	60min
VI	—	—	—	+∞

### Lumière de jour 2

Ceci n'est applicable que dans le mode 2.

Il se réfère au niveau de la lumière du jour auquel le luminaire au niveau bas s'allume.

	3	4	5	
I	ON	ON	ON	Disable
II	—	ON	ON	150Lux
III	ON	—	ON	100Lux
IV	—	—	ON	75Lux
V	ON	—	—	50Lux
VI	—	—	—	35Lux

### Temps de suivi

Ceci détermine le temps pendant lequel le luminaire reste allumé à 100%. Ceci peut être réglé avec les micro-interrupteurs sur le capteur, voir la figure ci-dessous. Lors de l'installation du luminaire, le réglage du test de marche (5s) est utile afin de déterminer le fonctionnement et la portée correcte.

	3	4	5	
I	ON	ON	ON	5s
II	—	ON	ON	30s
III	ON	—	ON	1min
IV	—	—	ON	5min
V	ON	ON	—	15min
VI	—	—	—	30min

### Lumière de jour 1

Ceci permet au capteur d'allumer le luminaire lorsque la lumière ambiante est en plein jour (15Lux), en basse lumière (10Lux) ou sombre (5Lux). Il permet également de désactiver le capteur. Ceci est réglé par des micro-interrupteurs sur le capteur, voir la figure ci-dessous. Tant que le niveau d'éclairage est supérieur à la valeur définie, le luminaire restera éteint pendant la détection de mouvement.

	1	2	
I	ON	ON	Disable
II	—	ON	15Lux
III	ON	—	10Lux
IV	—	—	5Lux

### Mode

Mode 1: Le luminaire restera éteint pendant la détection de mouvement si le niveau de lumière du jour est supérieur à la valeur réglée sur "Lumière de jour 1".  
Mode 2: Si le niveau de la lumière de jour tombe en dessous de la valeur réglée sur "Lumière de jour 2", le luminaire s'allume au niveau bas. En cas de détection de mouvement, il passera à 100%.

	6	
I	ON	Mode 1
II	—	Mode 2

# CAPTEUR DE MICRO-ONDES - RÉGLAGE DES PARAMÈTRES

## A 0% / 100% / 20%

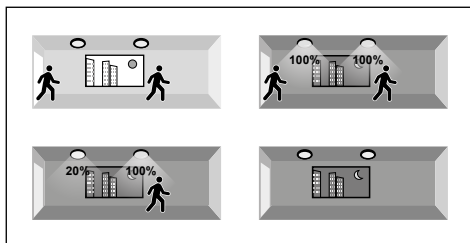

**M** Mode

ON	6		
I	ON	Mode 1	✓
II	—	Mode 2	

**⌚** Temps de suivi

ON	6	7	8	
I	ON	ON	ON	0s
II	—	ON	ON	10min
III	ON	—	ON	20min
IV	—	—	ON	30min
V	ON	ON	—	60min
VI	—	—	—	+∞

## B 0% / 100%

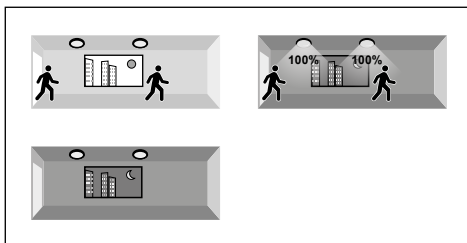

**M** Mode

ON	6		
I	ON	Mode 1	✓
II	—	Mode 2	

**⌚** Temps de suivi

ON	6	7	8	
I	ON	ON	ON	0s
II	—	ON	ON	10min
III	ON	—	ON	20min
IV	—	—	ON	30min
V	ON	ON	—	60min
VI	—	—	—	+∞

## C 20% / 100%

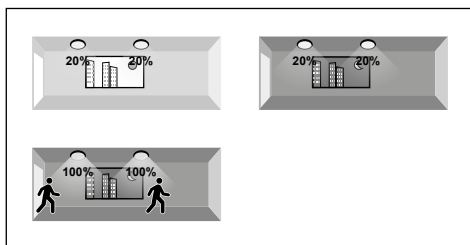

**M** Mode

ON	6		
I	ON	Mode 1	✓
II	—	Mode 2	

**⌚** Temps de suivi

ON	6	7	8	
I	ON	ON	ON	0s
II	—	ON	ON	10min
III	ON	—	ON	20min
IV	—	—	ON	30min
V	ON	ON	—	60min
VI	—	—	—	+∞

## D 0% / 20% basé sur la lumière du jour / 100% en cas de mouvement

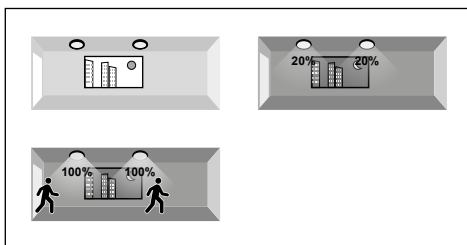

**M** Mode

ON	6		
I	ON	Mode 1	✓
II	—	Mode 2	



## CHOIX DE LA SORTIE DE LUMIÈRE

Vous pouvez définir l'appareil à 2 valeurs Lumen différentes:

ON - 600Lm (standard)

1 - 300Lm

L'interrupteur se trouve à côté du module LED et peut être vu lorsque vous avez retiré le capuchon de protection.

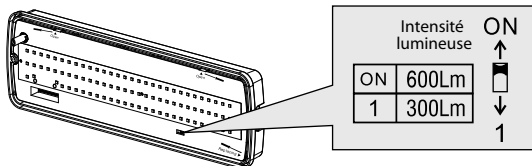

## FONCTION MAÎTRE / ESCLAVE

### Fonction A

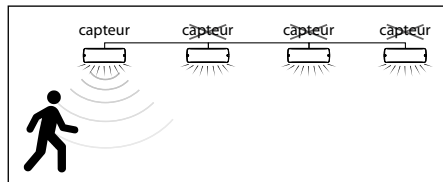

### Fonction B

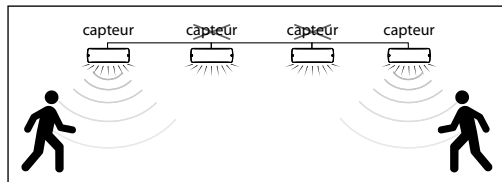

### Fonction A - Commutation centralisée

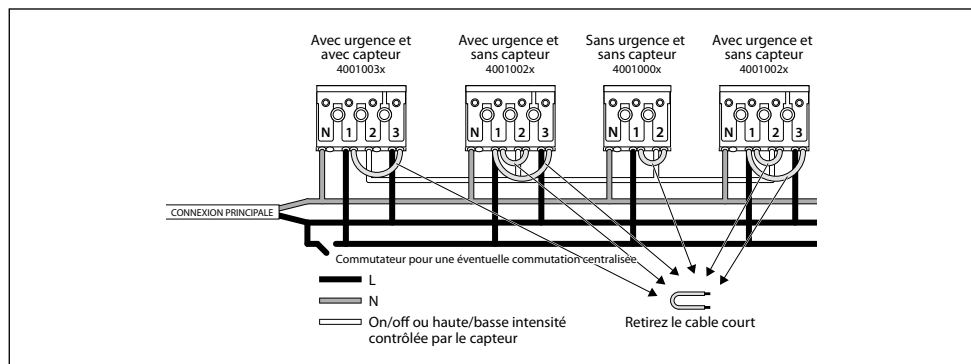

### Fonction B - Seulement commuté au moyen de capteurs intégrés

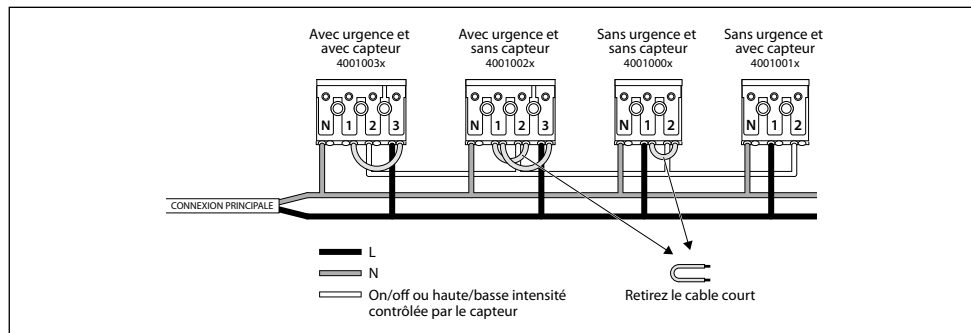

**Le nombre d'unités dans la fonction esclave est limité. (Max 60 pièces)**

## INSTALLATION

1. Dévissez le blindage et ouvrez le panneau LED.
2. Passer le câble à travers le thule et le fixer avec le réducteur de tension.
3. Fixez l'appareil au moyen de vis sur la surface.
4. Connectez le câble de connexion au terminal correctement.
5. Branchez la fiche de la batterie à la connexion "Battery +/-" de l'unité d'urgence. ⚠
6. Fermez le panneau LED et fixez le blindage

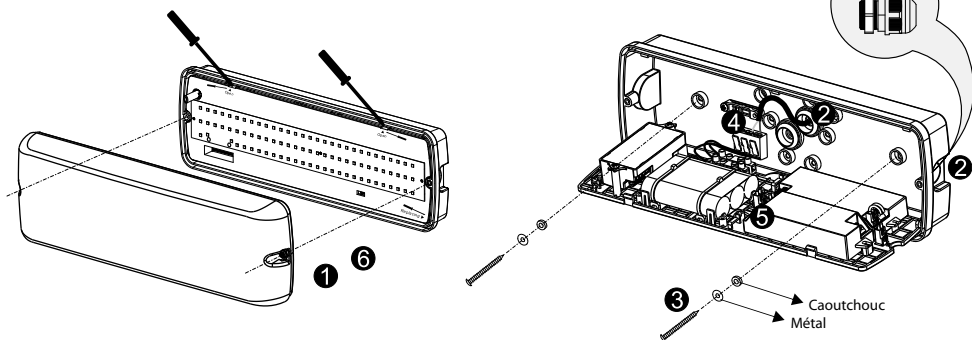

### 4 Câble de connexion

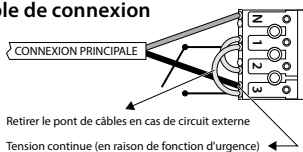

Version d'urgence

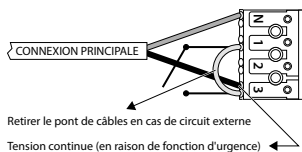

Urgence + version du capteur  
(phase commutée non requise)

## TESTER

Testez la fonction d'urgence après l'installation.

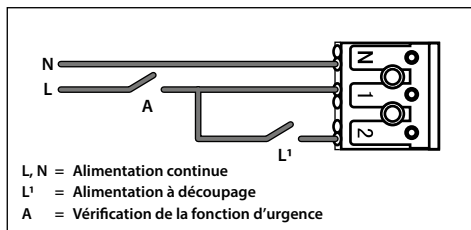

## ACCESSOIRES - SYMBOLES DE SORTIE DE SECOURS



40010040

Sortie de secours  
En haut



40010041

Sortie de secours  
Down



40010042

Sortie de secours  
Gauche



40010043

Sortie de secours  
Droit

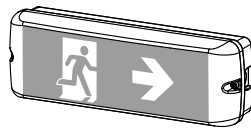

## REPLACER LA BATTERIE

1. Mettez d'abord le luminaire hors tension.
2. Retirez la fiche de la batterie de l'unité d'urgence.
3. Retirez les attaches en plastique.
4. Retirez la vieille batterie.
5. Fixez la nouvelle batterie en utilisant les fixations en plastique.
6. Connectez la fiche à l'unité d'urgence.
7. Notez la date de mise en service de la batterie.

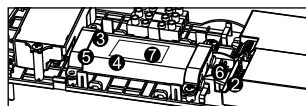

## REPLACER LE TRAVAIL INTÉRIEUR

**⚠ Mettez d'abord le luminaire hors tension.**

1. Détachez le capuchon de protection, puis retirez le pilote LED avec un tournevis.
2. Séparez les fiches mâle-femelle et retirez l'ancien travail intérieur.
3. Installez le nouveau travail intérieur puis branchez fermement les fiches mâles-femelles.
4. Fixez le capuchon de protection.

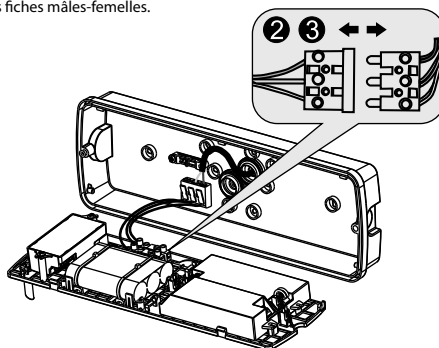
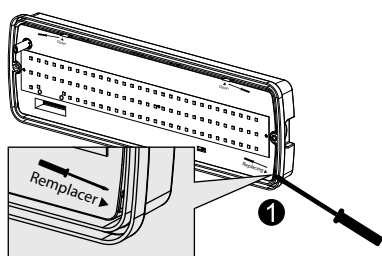

## ENTRETIEN

1. Couper la tension du luminaire.
2. Ne touchez pas les LED pendant l'entretien ou le nettoyage.
3. N'utilisez pas de produits de nettoyage chimiques pour nettoyer le luminaire.

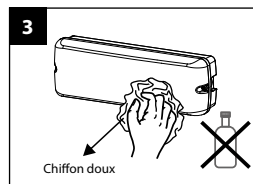
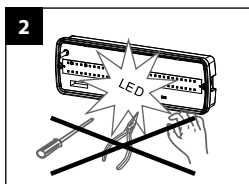
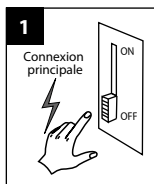

## PROTECTION DE L'ENVIRONNEMENT

Les appareils électriques défectueux ne doivent pas être jetés avec les ordures ménagères. Recycler si possible. Contactez votre municipalité ou votre fournisseur pour obtenir des conseils spécialisés en matière de recyclage.



## UPOZORNĚNÍ

Prosíme, přečtěte si pozorně návod k použití před začátkem instalace. Tento návod k použití si uchovejte pro případnou budoucí potřebu.

## UPOZORNĚNÍ

1. Instalace může být provedena pouze kvalifikovaným pracovníkem. Přívod proudu musí být odpojen před začátkem instalace.
2. Průřez vodičů připojovacího vedení musí být min.  $2 \times 1,0 \text{ mm}^2$  a zapojení dle IEE mezinárodních elektrických regulací.
3. Odpojte přívod elektrického proudu před výměnou baterie.
4. Nedotýkejte se elektrického obvodu a jeho komponentů.
5. Při poškození či nefunkčnosti LED osvětlení je nutná výměna celého svítidla.
6. Pokud svítidlo nesvítilí minimálně 1 hodinu při provozu na baterii, baterie musí být vyměněna.
7. Kód pro identifikaci výroby baterie: např. 1810= 2018, týden 10.
8. Nedotýkejte se LED diod během instalace ani při údržbě.
9. LED zdroj svítidla nemůže být vyměněn. Při poruše musí být vyměněno celé svítidlo.
10. Pokud baterie není připojena k hlavnímu zdroji napětí dochází k vybíjení a tím i snížení kapacity baterie. Delší odpojení od zdroje může baterii poškodit. Při porušení této zásady nelze uznat záruku.
11. Během výstavby mohou být elektrické okruhy opakovaně odpojovány, čímž je způsobeno časté nabíjení a vybíjení baterie vedoucí ke snížení životnosti a může způsobit i její předčasné selhání. Reklamacе týkající se baterie používané za těchto podmínek jsou výslovně vyloučeny z podmínek záruky.

## TECHNICKÁ DATA

Napájení : AC 220-240V 50/60Hz  
Světelný zdroj: LED SMD2835  
Baterie: Ni-Cd Výdrž: 1h  
Provozní teplota: -20°C - +50°C  
Třída ochrany: Třída II

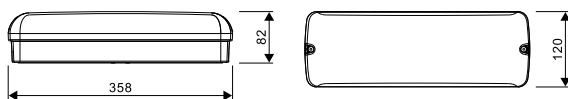

## TECHNICKÉ INFORMACE

Obj.č.	Typ LED	Příkon	Světelný tok přepínatelně	Světelný tok v nouzovém režimu	Senzor	Pracovní mód	Výdrž	Baterie
4001002x	SMD2835	7,5W	600Lm / 300Lm	200Lm	-	(Ne-)permanentní (přepínatelný)	1h	Ni-CD 2/3AA450mAhHT 7.2V
4001003x	SMD2835	8,5W	600Lm / 300Lm	200Lm	Ano	(Ne-)permanentní (přepínatelný)	1h	Ni-CD 2/3AA450mAhHT 7.2V

## MIKROVLNNÝ SENZOR - POPIS

Detekční zóna max. (š x v): 14m x 6m

Citlivost detekce: 25% - 100%, lze přizpůsobit

Doba plného osvětlení: 5 s - 30 min, lze přizpůsobit

Režim denního osvětlení 1:

5 - 15Lux, lze přizpůsobit nebo vypnout

Režim denního osvětlení 2:

35 - 150Lux, lze přizpůsobit nebo vypnout  
(s prioritou denního osvětlení)

Doba plného osvětlení:

5 - 30 s - 1 - 5 - 15 - 30 min, lze přizpůsobit

Doba orientačního osvětlení:

0 - 10 - 20 - 30 - 60 - ∞ min, lze přizpůsobit

Montážní výška: 6m max.

Detektor pohybu: 0.5 ~ 3m/s

Uhel detekce: 150° (nástěnná montáž),

360° (stropní montáž)

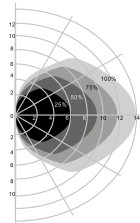

Oblast detekce při nástěnné montáži (Jednotka: m)  
Doporučená montážní výška: 1 - 1.8m

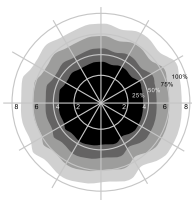

Oblast detekce při stropní montáži (Jednotka: m)  
Doporučená montážní výška: 2.5 - 6m

## NASTAVENÍ PARAMETRŮ MV SENZORU

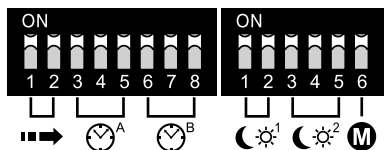

### ➡ Oblast detekce

Tato funkce definuje rozsah detektoru pohybu a je nastavitelná pomocí přepínačů na senzoru, viz náčrty níže. Redukce citlivosti také zúží oblast detekce.

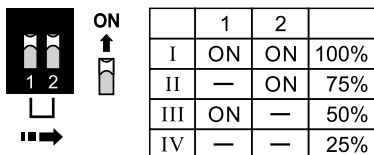

### ⌚<sup>B</sup> Doba orientačního osvětlení

Během této doby bude svítidlo vydávat slabé osvětlení (20%). Při volbě + ∞ svítidlo vydává 20% osvětlení vždy, pokud není zaznamenán pohyb. Lze nastavit pomocí přepínačů na senzoru, viz náčrty níže.

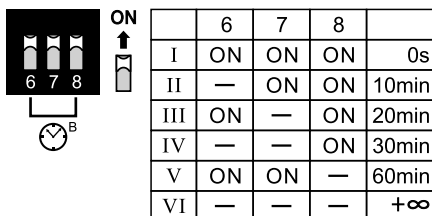

### ☀<sup>2</sup> Režim denního osvětlení 2

Tato funkce lze spustit pouze v módu 2.

Svítidlo vydá slabé osvětlení při denním osvětlení.

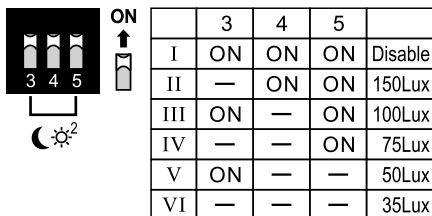

### ⌚<sup>A</sup> Doba plného osvětlení

Tato funkce definuje čas, po který svítidlo vydává 100% osvětlení a je nastavitelná pomocí přepínačů na senzoru, viz náčrty níže. Při instalaci je vhodné dobu spuštění vyzkoušet průchodem pod senzorem pro zvolení vhodného nastavení.

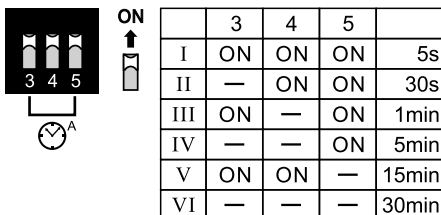

### ☀<sup>1</sup> Režim denního osvětlení 1

Tato funkce umožňuje zapnutí senzoru v závislosti na intenzitě denního osvětlení. Plné denní osvětlení (15 Lux), přitmy (10 Lux), po setmění (5 Lux). Také možnost vypnutí senzoru. Při vyšší intenzitě denního osvětlení než bylo zvoleno na senzoru, zůstane svítidlo vypnuté i při zaznamenaní pohybu.

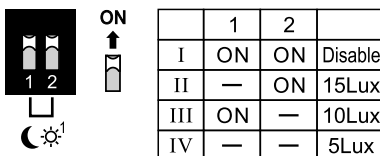

### Ⓜ Mód

Mód 1: Svítidlo zůstane vypnuté při detekci pohybu pokud intenzita denního osvětlení přesahuje hodnotu nastavenou jako "Režim denního osvětlení 1".

Mód 2: Pokud intenzita denního osvětlení klesne pod hodnotu nastavenou jako "Režim denního osvětlení 2", svítidlo vydá slabé osvětlení. Při detekci pohybu zvýší osvětlení na 100%.

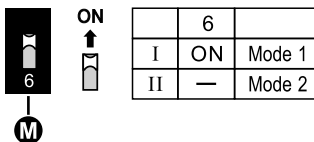

# NASTAVENÍ PARAMETRŮ MV SENZORU

## A 0% / 100% / 20%

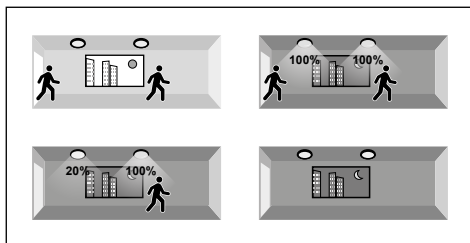

**M** Mód

ON	6		
I	ON	Mode 1	✓
II	—	Mode 2	

**Doba osvětlení**

ON	6	7	8	
I	ON	ON	ON	0s
II	—	ON	ON	10min
III	ON	—	ON	20min
IV	—	—	ON	30min
V	ON	ON	—	60min
VI	—	—	—	+∞

## B 0% / 100%

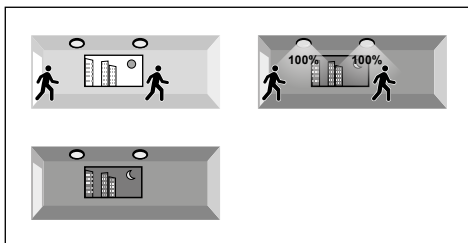

**M** Mód

ON	6		
I	ON	Mode 1	✓
II	—	Mode 2	

**Doba osvětlení**

ON	6	7	8	
I	ON	ON	ON	0s
II	—	ON	ON	10min
III	ON	—	ON	20min
IV	—	—	ON	30min
V	ON	ON	—	60min
VI	—	—	—	+∞

## C 20% / 100%

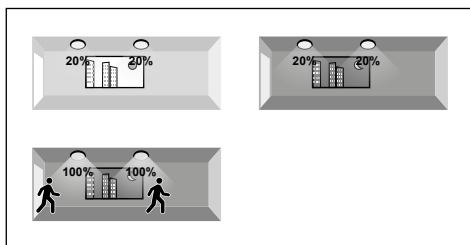

**M** Mód

ON	6		
I	ON	Mode 1	✓
II	—	Mode 2	

**Doba osvětlení**

ON	6	7	8	
I	ON	ON	ON	0s
II	—	ON	ON	10min
III	ON	—	ON	20min
IV	—	—	ON	30min
V	ON	ON	—	60min
VI	—	—	—	+∞

## D 0% / 20% v závislosti na denním osvětlení / 100% při detekci pohybu

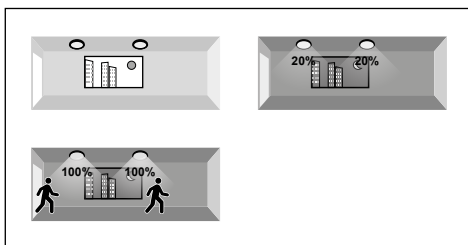

**M** Mód

ON	6		
I	ON	Mode 1	✓
II	—	Mode 2	

## MOŽNOSTI NASTAVENÍ SVÍTIVOSTI

Volba intenzity svítivosti pomocí přepínače umístěného na desce LED diod:

ON - 600Lm (standard)

1 - 300Lm

Přepínač je umístěn vedle LED modulu a je dostupný po odstranění ochranného krytu.

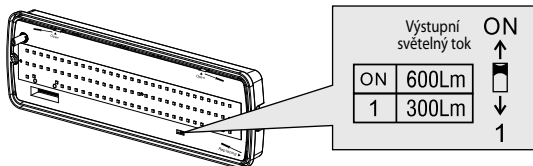

## FUNKCE MASTER/SLAVE

### Funkce A

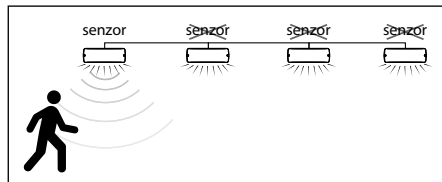

### Funkce B

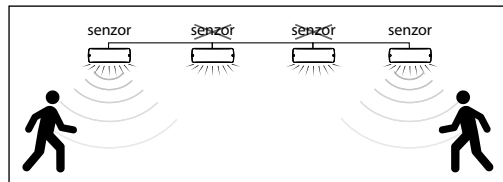

### Funkce A - Centrální spínání

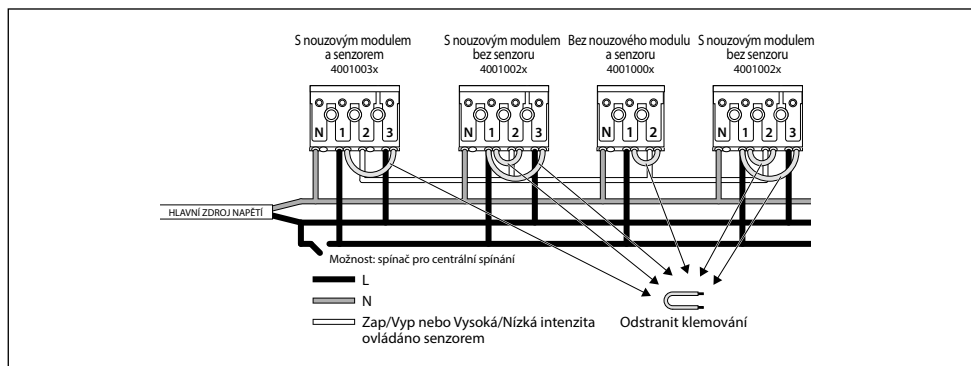

### Funkce B - Spínání pouze pomocí vestavěných čidel

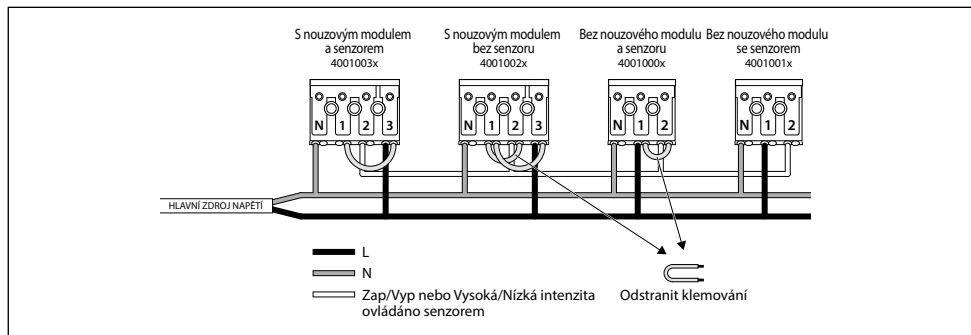

Počet svítidel ve funkci Slave je omezen. (Max. 60 ks)

23

## MONTÁŽ

1. Demontujte difuzor a desku s LED diodami.
2. Protáhněte přívodní kabel otvorem v krytu svítidla.
3. Umístěte svítidlo na požadované místo a zafixujte.
4. Správně zapojte kabel ke svorce.
5. Připojte pevně baterii k nouzovému modulu. 
6. Nasadte zpět difuzor a desku s diodami.

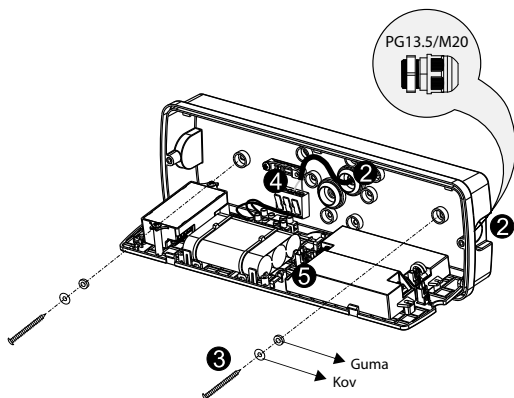
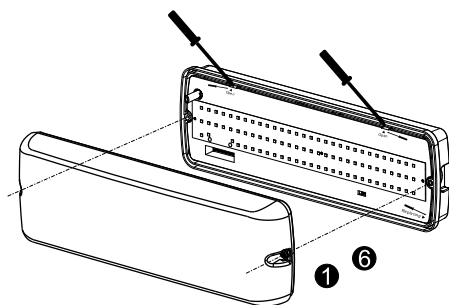

### 4 Připojení vodičů

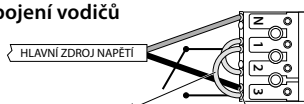

Odstranit klemování pro externí spínání  
Přerušení hlavního zdroje napětí ( pro funkci nouzové zálohy)

Nouzový modul

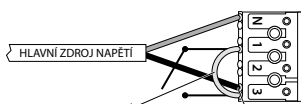

Odstranit klemování pro externí spínání  
Přerušení hlavního zdroje napětí ( pro funkci nouzové zálohy)

Nouzový modul + senzor  
(bez spínače)

## TEST

Vyzkoušejte nouzovou funkci po instalaci.

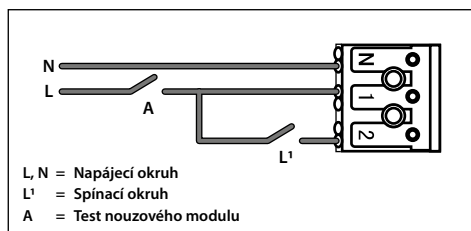

## PŘÍSLUŠENSTVÍ - OZNAČENÍ NOUZOVÉHO ÚNIKU



40010040  
Nouzový únik  
Nahoru



40010041  
Nouzový únik  
Dolů



40010042  
Nouzový únik  
Vlevo



40010043  
Nouzový únik  
Vpravo

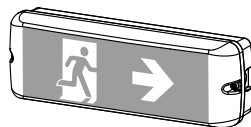



## VÝMĚNA BATERIE

1. Nejprve odpojte přívod napětí.
2. Odpojte baterie od nouzového modulu.
3. Odšroubujte plastové úchyty.
4. Odstraňte původní baterie.
5. Připevněte nové baterie plastovými úchyty.
6. Připojte baterie k nouzovému modulu.
7. Zaznamenejte si datum výměny baterií.

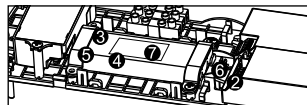

## VÝMĚNA ZDROJE SVĚTLA

**⚠ Nejprve odpojte přívod napětí.**

1. Otevřete difuzor, poté pomocí nástroje demontujte desku s LED diodami.
2. Oddělte svorku a vyjměte původní desku s LED diodami.
3. Připojte novou LED desku.
4. Nasadte difuzor.

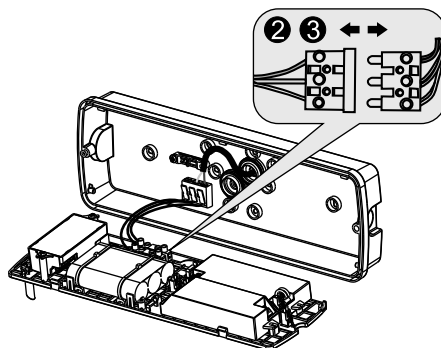
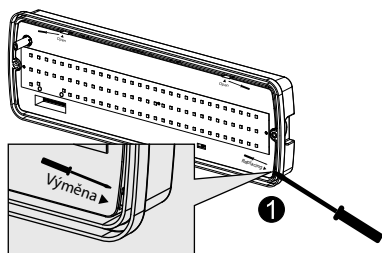

## ÚDRŽBA

1. Nejprve vypněte proud.
2. Nedotýkejte se LED diod při údržbě ani čištění.
3. Nepoužívejte chemické čisticí prostředky.

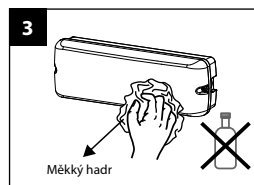
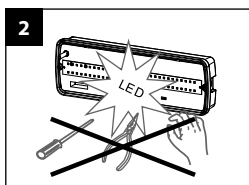
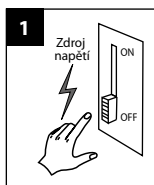

## OCHRANA ŽIVOTNÍHO PROSTŘEDÍ

Vyrážené elektronické přístroje nepatří do smíšeného odpadu. Prosíme recyklujte na místech tomu určených. Případně se poraďte s místním úřadem nebo svým prodejcem.



## ACHTUNG

Lesen Sie die folgende Anleitung bitte aufmerksam durch, um eine korrekte Ausführung der Montage zu gewährleisten. Bewahren Sie diese Anleitung zum späteren Nachschlagen gut auf.

## HINWEIS

1. Das Produkt muss durch einen qualifizierten Techniker installiert werden. Die Installation muss, vor der Montage, bei abgeschalteter Versorgungsspannung vorgenommen werden.
2. Die Leitung zur Spannungsversorgung muss einen Mindestquerschnitt von  $2 \times 1,0 \text{ mm}^2$  aufweisen und entsprechend den neusten IEE-Vorschriften oder den nationalen Vorschriften angeschlossen sein.
3. Schalten Sie die Spannungsversorgung des Treibers ab, bevor Sie den Akku austauschen.
4. Elektronische Schaltung und zugehörige Teile nicht berühren.
5. Falls eine Leuchtdauer von 1 Stunde nicht mehr erreicht wird, muss der Akku ausgetauscht werden.
6. Wenden Sie sich an den autorisierten Kundendienst, um den Akku austauschen zu lassen und verwenden Sie für andere Reparaturen nur Originalersatzteile.
7. ID-Code zum Herstellungsdatum des Akkus: z. B. 1810 – 2018, Woche 10.
8. LEDs bei Installation und Wartung nicht berühren.
9. Die LED-Lichtquelle kann nicht ausgetauscht werden. Wenn die Lichtquelle ausfällt, muss das gesamte Gerät ausgetauscht werden.
10. Durch Selbstentladung nimmt die Ladung des Akkus langsam ab, wenn das Gerät nicht mit dem Netz verbunden ist. Bei längerer Spannungslosigkeit kann der Akku beschädigt werden. Hierdurch verursachte Schäden fallen nicht unter die Garantie.
11. Auf vielen Baustellen können Stromkreise während der Bauarbeiten unkontrolliert und wiederholt unterbrochen werden. Dadurch können sich die Akkus entladen. Häufiges Laden und Entladen eines Akkus verkürzt seine Lebensdauer und kann zum vorzeitigen Ausfall führen. Hierdurch verursachte Schäden fallen nicht unter die Garantie.

## TECHNISCHE DATEN

Betriebsspannung: 220 – 240 V AC, 50/60 Hz

Lichtquelle: LED SMD2835

Akku: Ni-Cd Leuchtdauer: 1 h

Betriebstemperatur:  $-20 \text{ }^\circ\text{C}$  -  $+50 \text{ }^\circ\text{C}$

Schutzklasse: Klasse II

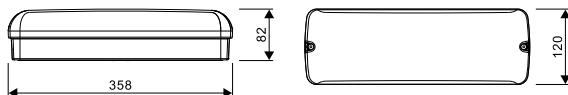

## TECHNISCHE INFORMATIONEN

Artikelnr.	LED-Typ	Leistung	Lichtstrom schaltbar	Lichtstrom im Notbetrieb	Sensor	Funktion	Dauer	Akku
4001002x	SMD2835	7,5W	600Lm / 300Lm	200Lm	-	(Nicht) permanent (schaltbar)	1 h	Ni-CD 2/3AA450mAhHT 7.2V
4001003x	SMD2835	8,5W	600Lm / 300Lm	200Lm	Ja	(Nicht) permanent (schaltbar)	1 h	Ni-CD 2/3AA450mAhHT 7.2V

## MIKROWELLEN-SENSOR - BESCHREIBUNG

Ansprechbereich max. (T x H). 14m x 6m

Ansprechempfindlichkeit: 25% - 100%, einstellbar

Leuchtdauer: 5s - 30 Minuten, einstellbar

Tageslicht 1: 5 - 15Lux, einstellbar oder ausschalten

Tageslicht 2: 35 - 150Lux, einstellbar oder ausschalten (bei Tageslichtergänzung)

Nachlaufzeit: 5 - 30s - 1 - 5 - 15 - 30 Minuten (einstellbar)

Nachlaufzeit Orientierungsbeleuchtung:

0 - 10 - 20 - 30 - 60 -  $\infty$  Minuten (einstellbar)

Montagehöhe max. 6 m

Bewegungserkennung: 0,5 bis 3m/s

Erkennungswinkel:  $150^\circ$  (Wandmontage),

$360^\circ$  (Deckenmontage)

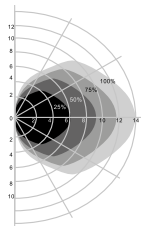

Ansprechbereich Wandmontage (Einheit: m)  
Empfohlene Montagehöhe: 1 - 1,8m

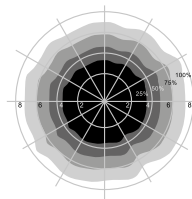

Ansprechbereich Deckenmontage (Einheit: m)  
Empfohlene Montagehöhe: 2,5 - 6m

## MIKROWELLEN-SENSOR - EINSTELLEN DER PARAMETER

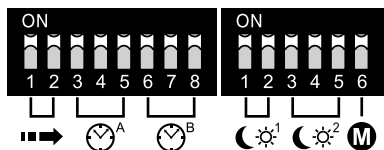

### Ansprechbereich

Diese Einstellung bestimmt den Ansprechbereich des Bewegungsmelders. Hierzu dienen die DIP-Schalter am Sensor, siehe Abbildung unten. Beachten Sie bitte, dass sich bei geringerer Empfindlichkeit auch der Ansprechbereich verkleinert.

	1	2	
I	ON	ON	100%
II	—	ON	75%
III	ON	—	50%
IV	—	—	25%

### Nachlaufzeit

Dies ist die Zeit, während der die Leuchte mit 100% Helligkeit leuchtet. Die Einstellung erfolgt an den DIP-Schaltern am Sensor, siehe Abbildung unten. Während der Installation der Leuchte ist die Einstellung Laufzeit (5s) eine praktische Hilfe, um die korrekte Funktion im gewünschten Bereich zu überprüfen.

	3	4	5	
I	ON	ON	ON	5s
II	—	ON	ON	30s
III	ON	—	ON	1min
IV	—	—	ON	5min
V	ON	ON	—	15min
VI	—	—	—	30min

### Nachlaufzeit, Orientierungsbeleuchtung

Während dieser Zeit leuchtet die Leuchte mit niedriger Helligkeit (20%). Wenn hier der Wert  $+\infty$  eingestellt ist, brennt die Leuchte ständig mit einer Helligkeit von 20%, wenn keine Bewegung erkannt wird. Die Einstellung erfolgt an den DIP-Schaltern am Sensor, siehe Abbildung unten.

	6	7	8	
I	ON	ON	ON	0s
II	—	ON	ON	10min
III	ON	—	ON	20min
IV	—	—	ON	30min
V	ON	ON	—	60min
VI	—	—	—	$+\infty$

### Tageslicht 1

Hierbei schaltet der Sensor die Leuchte ein, wenn in der Umgebung helles Tageslicht (15Lux), wenig Tageslicht (10Lux) oder fast Dunkelheit (5Lux) herrscht. Der Sensor kann hier auch ausgeschaltet werden. Solange die Helligkeit oberhalb des eingestellten Werts liegt, schaltet die Leuchte bei erkannter Bewegung nicht ein.

	1	2	
I	ON	ON	Disable
II	—	ON	15Lux
III	ON	—	10Lux
IV	—	—	5Lux

### Tageslicht 2

Dies gilt nur in Modus 2. Es handelt sich um die Tageslichthelligkeit, bei der die Leuchte mit niedriger Helligkeit leuchtet.

	3	4	5	
I	ON	ON	ON	Disable
II	—	ON	ON	150Lux
III	ON	—	ON	100Lux
IV	—	—	ON	75Lux
V	ON	—	—	50Lux
VI	—	—	—	35Lux

### Modus

Modus 1: Die Leuchte schaltet bei erkannter Bewegung nicht ein, wenn die Helligkeit des Tageslichts über dem bei "Tageslicht 1" eingestellten Wert liegt.

Modus 2: Falls die Helligkeit des Tageslichts unter den bei "Tageslicht 2" eingestellten Wert absinkt arbeitet die Leuchte mit niedriger Helligkeit. Bei erkannter Bewegung wird auf 100% umgeschaltet.

	6	
I	ON	Mode 1
II	—	Mode 2

# MIKROWELLEN-SENSOR - EINSTELLEN DER PARAMETER

## A 0% / 100% / 20%

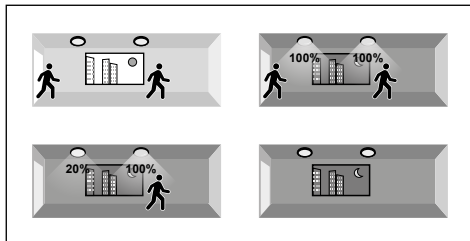

**M** Modus 

ON	6	
I	ON	Mode 1
II	—	Mode 2

 ✓

**Nachlaufzeit**

ON	6	7	8	
I	ON	ON	ON	0s
II	—	ON	ON	10min
III	ON	—	ON	20min
IV	—	—	ON	30min
V	ON	ON	—	60min
VI	—	—	—	+∞

 ✓✓✓✓

## B 0% / 100%

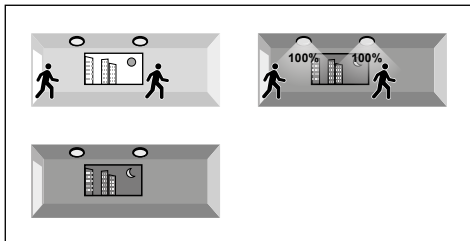

**M** Modus 

ON	6	
I	ON	Mode 1
II	—	Mode 2

 ✓

**Nachlaufzeit**

ON	6	7	8	
I	ON	ON	ON	0s
II	—	ON	ON	10min
III	ON	—	ON	20min
IV	—	—	ON	30min
V	ON	ON	—	60min
VI	—	—	—	+∞

 ✓

## C 20% / 100%

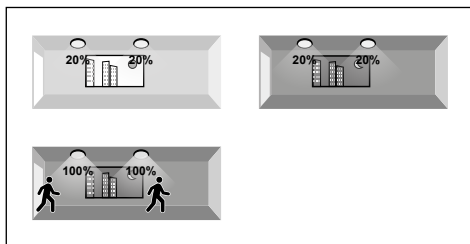

**M** Modus 

ON	6	
I	ON	Mode 1
II	—	Mode 2

 ✓

**Nachlaufzeit**

ON	6	7	8	
I	ON	ON	ON	0s
II	—	ON	ON	10min
III	ON	—	ON	20min
IV	—	—	ON	30min
V	ON	ON	—	60min
VI	—	—	—	+∞

 ✓

## D 0% / 20% je nach Tageslicht / 100% bei Bewegung

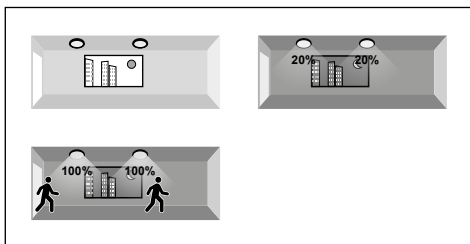

**M** Modus 

ON	6	
I	ON	Mode 1
II	—	Mode 2

 ✓

## AUSWAHL DER HELLIGKEIT

Sie können an der Leuchte zwei verschiedene Lumen-Werte einstellen:

ON - 600Lm (Standard)

1 - 300Lm

Der Schalter befindet sich neben dem LED-Modul und wird nach Abnehmen der Blende zugänglich.

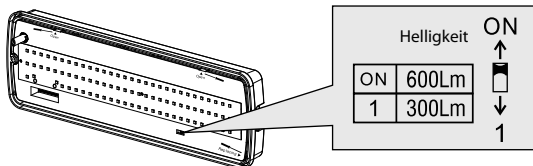

## MASTER/SLAVE FUNKTION

### Funktion A

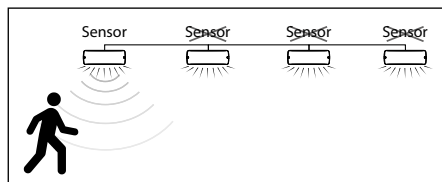

### Funktion B

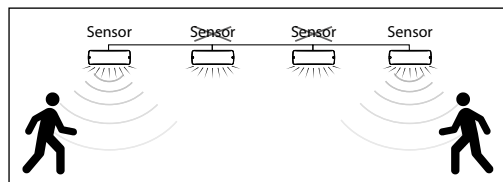

### Funktion A - Zentral geschaltet

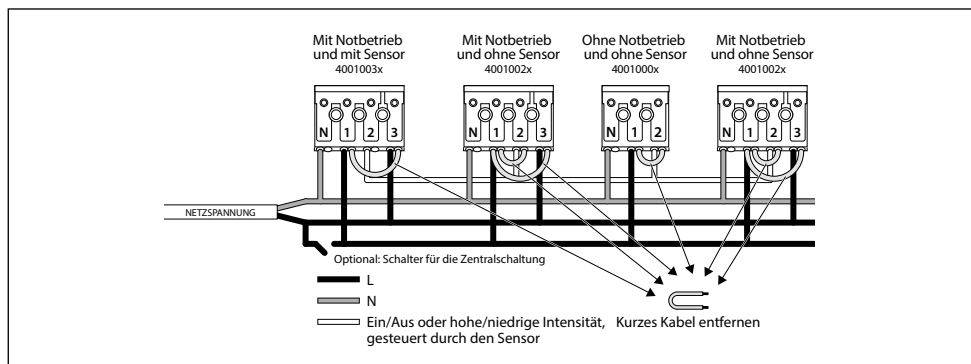

### Funktion B - Nur über eingebaute Sensoren schaltbar

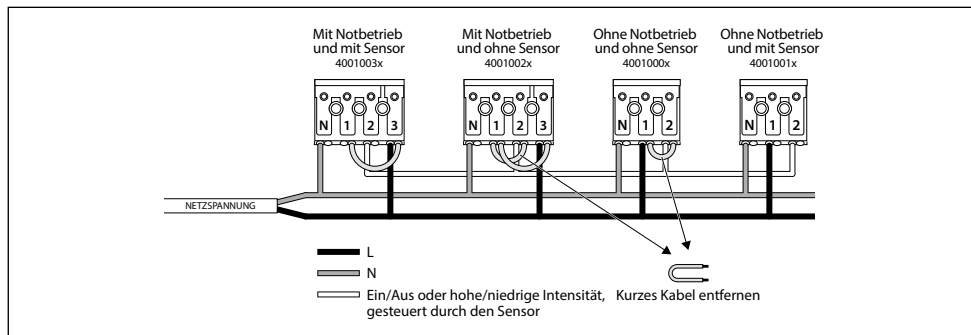

⚠ Die Anzahl der Slaves ist begrenzt. (Max. 60 Stück)

## MONTAGE

1. Schrauben Sie die Blende ab und öffnen Sie das LED-Panel.
2. Führen Sie das Anschlusskabel durch die Tülle und fixieren Sie es mit der Zugentlastung.
3. Befestigen Sie die Leuchte mit Schrauben auf der Montagefläche.
4. Schließen Sie das Anschlusskabel korrekt an den Klemmen an.
5. Verbinden Sie den Stecker des Akkus mit dem Anschluss "Battery +/-" an der Notstromversorgung. 
6. Schließen Sie das LED-Panel und befestigen Sie die Blende.

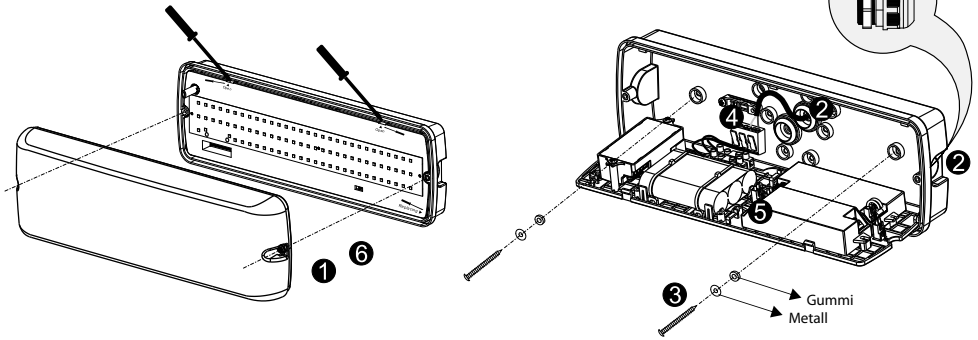

### 4 Anschluss des Kabels

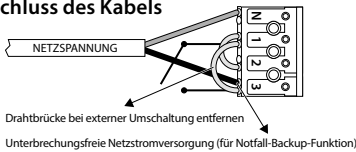

Version mit Notbetrieb

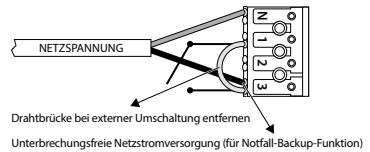

Version mit Notbetrieb und Sensor  
(geschaltete Phase nicht unbedingt erforderlich)

## TESTS

Tests des Notbetriebs nach der Installation.

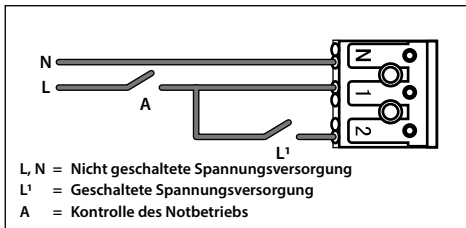

## ZUBEHÖR - NOTAUSGANGSSYMBOL



40010040  
Notausgang  
Nach oben



40010041  
Notausgang  
Nach unten



40010042  
Notausgang  
Links



40010043  
Notausgang  
Rechts

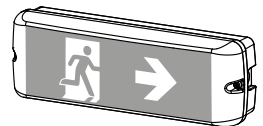

## AKKU AUSTAUSCHEN

1. Spannungsversorgung der Leuchte unterbrechen.
2. Stecker des Akkus aus der Notstromversorgung ziehen.
3. Kunststoffhalter entfernen.
4. Alten Akku entnehmen.
5. Neuen Akku mit den Kunststoffhaltern befestigen.
6. Stecker mit der Notstromversorgung verbinden.
7. Datum der Inbetriebnahme des Akkus notieren.

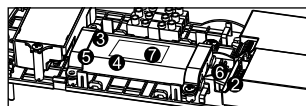

## KOMPONENTEN IM INNEREN AUSTAUSCHEN

### ! Spannungsversorgung der Leuchte unterbrechen.

1. Blende lösen, anschließend mit einem Schraubendreher den LED-Treiber entfernen.
2. Stecker und Kupplung trennen und alte Komponenten im Inneren entfernen.
3. Neue Komponenten im Inneren montieren und Stecker und Kupplung fest miteinander verbinden.
4. Blende anbringen.

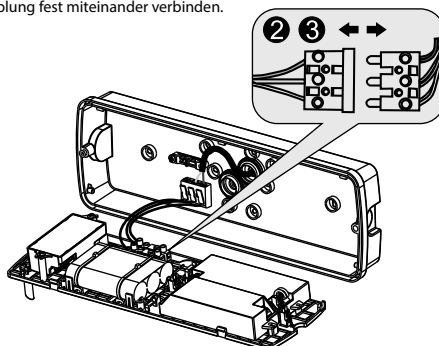
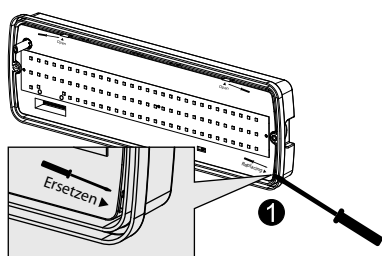

## WARTUNG

1. Spannungsversorgung der Leuchte unterbrechen.
2. LEDs bei Installation und Wartung nicht berühren.
3. Zur Reinigung der Leuchte keine Chemikalien verwenden.

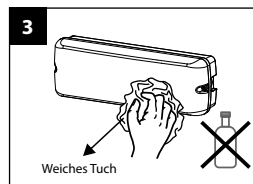
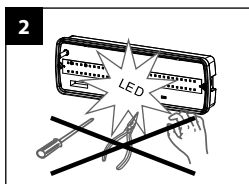

## UMWELTSCHUTZ

Defekte Elektrogeräte dürfen nicht über den Hausmüll entsorgt werden. Führen Sie sie, falls möglich, dem Recycling zu. Für weitere Hinweise zum Recycling wenden Sie sich bitte an Ihre Gemeinde oder Ihren Lieferanten.



# PROLUMIA®

## IMPORTER

### **NEDELKO B.V.**

Riga 10

2993 LW BARENDRECHT

**T** +31 (0)180 64 54 00

**E** info@nedelko.nl

### **NEDELKO BELGIUM NV**

Prins Boudewijnlaan 49

2650 EDEGEM

**T** +32 (0)3 826 99 99

**E** info@nedelko.be

### **NEDELKO S.R.O.**

Purkyňova 74/2

110 00 PRAHA 1 - NOVÉ MĚSTO

**T** +420 222 563 003

**E** info@nedelko.cz

### **NEDELKO GERMANY GMBH**

Heinz-Bäcker-Str. 27

45356 ESSEN

**T** +49 (0)201 560503 50

**E** info@nedelko.de